

**PHOENIX
SYSTEMS**

USER'S MANUAL

Universal Cap Adapter for Hydraulic System Bleed and Flush



Phoenix System Universal Cap Adapter (UCA) is designed to seal almost any brake or clutch master cylinder with a screw cap reservoir. The UCA, when used with any Phoenix Injector™, allows the technician to bleed or flush 90% of all screw cap systems. No longer is a host of adapters required to interface with reservoirs found on Bosch ABS, Delco and Teves, to name a few. The bladder is pressurized with brake fluid to seal openings up to 2½ inches in diameter.

Features

Bladder Inflates To Seal Almost Any Reservoir



This is a cut-away of a screw cap master cylinder reservoir. Notice how the bladder expands to seal the opening. Fluid passes through the center opening.

- Allows the Phoenix Injector™ to be used for pressure bleeding single inlet master cylinders.
- Provide automatic fluid replenishment during vacuum bleeding.
- Direct overflow into a capture container during the RFI™ process to eliminate secondary draining of the reservoir.
- Modular design allows easy interface with any Phoenix Injector™.
- Can be used with other vacuum or pressure bleeders (special adapters may be required).

Operation

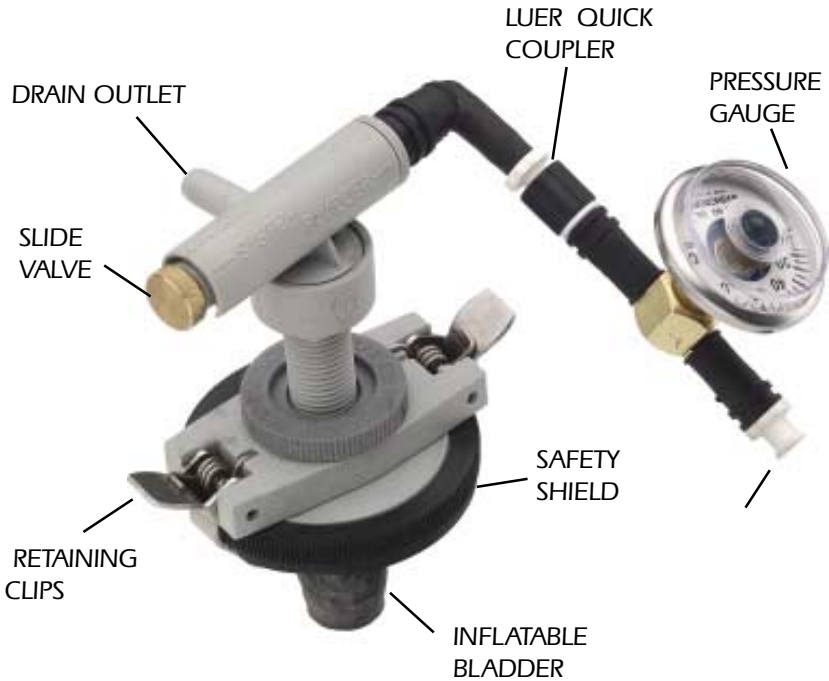

The UCA consists of the following main parts...

- The bladder which expands to adapt the UCA to the inlet of the master cylinder.
- The Spring loaded retaining clips which secure the UCA to the inlet neck of the master cylinder.
- The safety shield.
- The position of the slide valve and relief valve screw allow the bladder to be inflated and deflated and also allows the master cylinder to be pressurized.
- The pressure gauge displays the pressure of the bladder or hydraulic system being serviced, depending on the position of the slide valve.
- The safety shield and retaining clip can be adjusted independently. This allows for greater versatility in adapting to various neck sizes.

Maximum System Pressure is 60 psi.

Operation

Prior to Pressurizing the Reservoir

1. Inspect the reservoir neck for sharp obtrusions. Some float stops have sharp edges. If sharp obtrusions can't be safely removed DO NOT use.
2. To ensure secure fitting and positive sealing it is important that the UCA be adjusted so two-thirds of the bladder is below the lower flange of the reservoir neck before being inflated (See Fig. 1.3). If there is not sufficient room to insert the bladder two-thirds below the lower flange, pressurize the system slowly to test for proper seal.

3. To ensure this setting is correct, use the following steps:

Adjust Bladder height

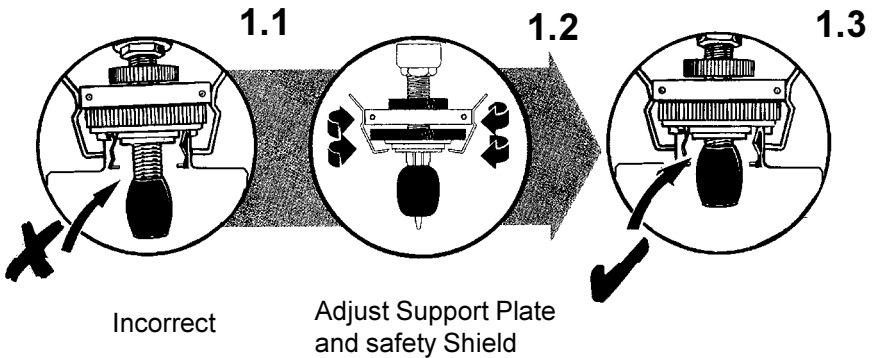

Adjust Retaining Clip

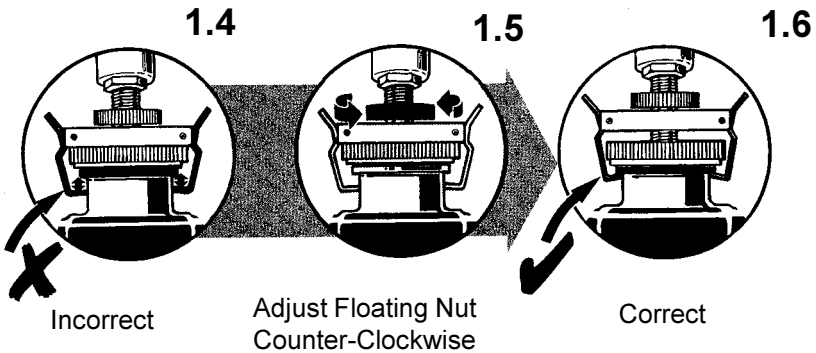

NOTE: In some applications, slight bending of the retaining clip for longer reach will improve attachment.

Operation

How to use the UCA for pressure bleeding single inlet master cylinders.

2.0 Prepare the Injector for pressure bleeding.

Inflate
Bladder
and Test
System

2.1 Move slide valve to system position

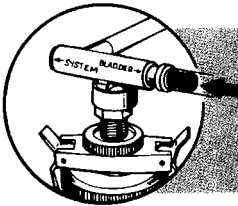

2.2 Adjust pressure bleed screw clockwise until firm- do not over tighten

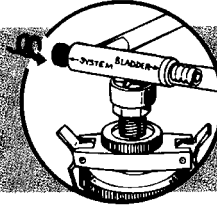

2.3 Move slide valve to bladder position

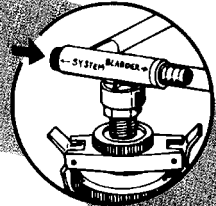

2.6

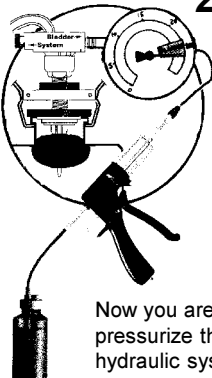

Now you are ready to pressurize the hydraulic system

2.5

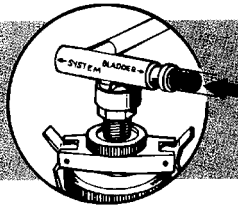

Move slide valve to system position

2.4

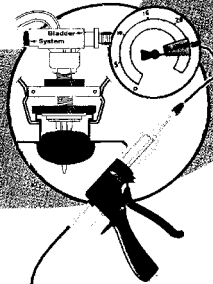

Operate injector to inflate the bladder to 25 psi (do not exceed this pressure)

NOTES:

- Bladder may be inflated with brake fluid or air.
- Maximum System Pressure is 60 psi.



Caution: Wear Eye Protection.

Pressure Bleeding/Flushing

1. Attach the capture container to the first wheel in the bleed sequence, or to the slave bleeder valve, making sure to use the capture assembly with one way check valve.
2. Open the bleeder valve. Using slow steady strokes apply pressure to the system. This will pressurize the reservoir and force fluid out the open bleeder valve into the capture container.
3. Repeat this process at each of the wheels in the sequence until all the old fluid has been flushed from the system and all the air has been removed.

 Caution: Wear Eye Protection.

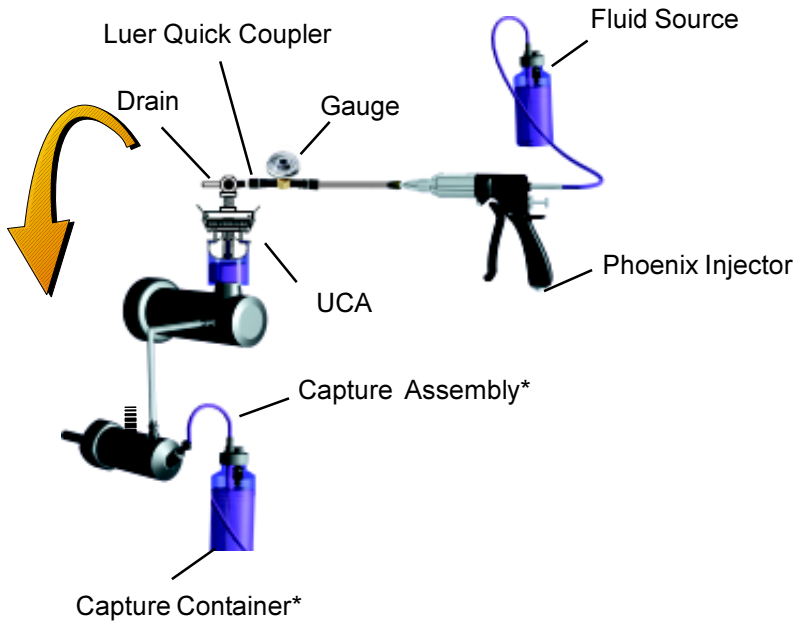

The UCA is attached to the reservoir and inflated with brake fluid. The Phoenix Injector™ pressurizes the reservoir and the fluid is forced out the bleeder valves into the capture container.

* Capture Container Caps and Capture Hose Assembly are included with the Phoenix Injector™ kit.

RFI & Vacuum Bleeding

VACUUM

To use the UCA to allow for automatic fluid replenishment during vacuum bleeding attach the UCA according to the previous steps.

Connect the new fluid source to the fluid inlet of the UCA as shown. This will allow fluid to be drawn into the reservoir during vacuum bleeding, avoiding the need to refill the reservoir during the process.

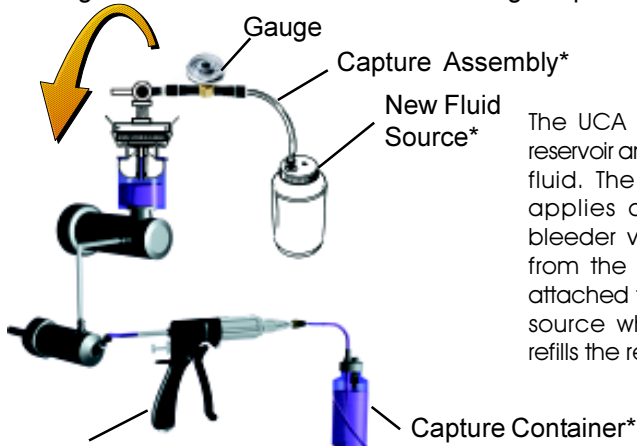

The UCA is attached to the reservoir and inflated with brake fluid. The Phoenix Injector™ applies a vacuum at the bleeder valve, drawing fluid from the system. The UCA is attached to a new brake fluid source which automatically refills the reservoir.

Phoenix Injector set up for vacuum bleeding.

RFI™

The UCA can also be used during the RFI™ bleeding process to avoid overfilling the reservoir. Simply connect an empty capture container to the fluid inlet of the UCA and proceed with the RFI process.

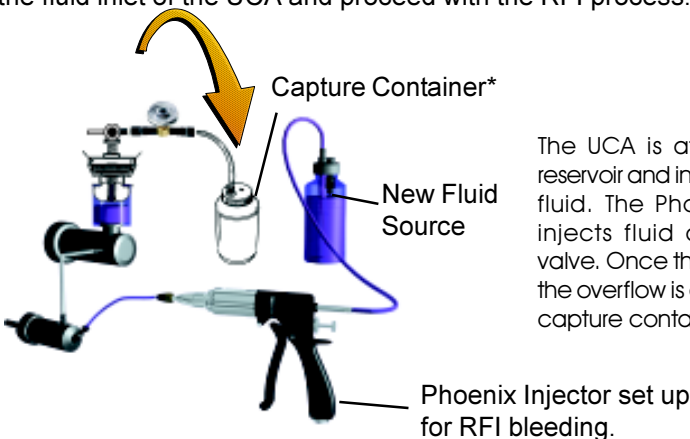

The UCA is attached to the reservoir and inflated with brake fluid. The Phoenix Injector™ injects fluid at the bleeder valve. Once the reservoir is full, the overflow is directed into the capture container.

* Capture Container Caps and Capture Hose Assembly are included with the Phoenix Injector™ kit.

Operation

3.0 Install drain hose to a capture container.

Release System Pressure and Deflate the Bladder

3.1 Adjust pressure bleed screw counter-clockwise

3.2 Allow pressure to release via the drain hose until gauge reads '0' psi.

3.3 Move slide valve to bladder position

3.4 The bladder is now deflated

3.5 release retaining clips and remove UCA.

Do not proceed to next step until gauge reads '0' psi

NOTES:

- When relieving system pressure: Connect a capture container to the relief valve outlet to collect the bladder or system fluid. With the slide valve in the System position, unscrew the relief valve counter-clockwise (CCW) until system pressure reads "0". Any residual system pressure will be dispersed through the relief valve outlet.
- Once bleeding has been completed disconnect the injector's fluid outlet from the UCA Luer Quick Coupler.

! DO NOT REMOVE THE LUER CONNECTION UNLESS THE SYSTEM PRESSURE IS 0 PSI OR FLUID MAY LEAK OUT.

! Caution: Wear Eye Protection.

Maintenance

Bladder Replacement

Refer to exploded view on page 11.

1. Remove center tube mounting screw (A) from the base of center tube (5).
2. Remove center tube flange (6).
3. Remove bladder (12) from stem (4).
4. Install new bladder onto stem using a twisting action. (Use brake fluid as a lubricant if required).
5. Install center tube flange.
6. Install center tube mounting screw with 'O'-ring and tighten fully.
Note: Do not over tension.
7. Inflate bladder to 25 psi three or four times to condition and stretch the material.
8. With bladder inflated immerse in water* or brake fluid to test for leaks.

NOTE: If bladder does not hold air refer to Trouble Shooting on page 10.

- * All traces of water must be removed prior to using the UCA to service a hydraulic system.

Trouble Shooting

Pressure Drop on Bladder Circuit

1. Check mounting of bladder to sleeve , center tube flange and stem .
2. Check tension of center tube mounting screw.
3. Check condition of pressure bleed screw and seat.
4. Check condition of slide valve “O” rings (see assembly #10).

Pressure Drop on System Circuit

1. First confirm the pressure drop is not due to a leak in the hydraulic system.
2. Check to be sure bladder size is adequate to seal reservoir neck. Condition bladder by inflating to 25 psi 3 times with the UCA off the vehicle.
3. Ensure correct adjustment of UCA as per instructions - see Page 4.

IT IS VERY IMPORTANT THAT THE UCA BE ADJUSTED SO THAT TWO-THIRDS OF THE BLADDER IS BELOW THE RESERVOIR SEALING SURFACE BEFORE BEING INFLATED.

4. Check condition of pressure bleed screw and seat.
5. Check condition of slide valve “O” rings (see assembly #10).

Exploded View

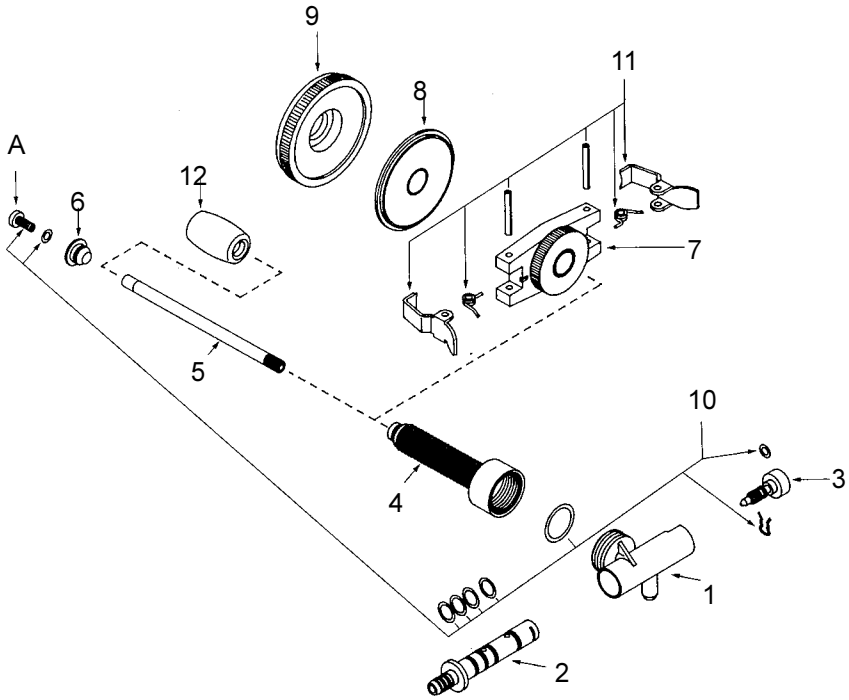

- | | | | |
|---|----------------------|----|---------------------------|
| 1 | Main Body | 7 | Support Plate |
| 2 | Slide Valve | 8 | Safety Shield |
| 3 | Pressure Bleed Screw | 9 | Safety Shield Seal |
| 4 | Stem | 10 | 'O'-Ring repair Kit |
| 5 | Center Tube | 11 | Retaining Clip Repair kit |
| 6 | Center Tube/Flange | 12 | Bladder Kit |

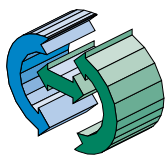

**PHOENIX
SYSTEMS**

strip it with strip dip

flush it with the **PHOENIX™
INJECTOR**



**Because Brake Fluid
Doesn't Last Forever!**

Phoenix Systems delivers innovative technology that works...What a concept!

Phoenix Systems L.L.C. www.phxsys.com
3555 E. 42nd Stravenue TUCSON, AZ. 85713
Technical Assistance 520-747-2020